

REVISION RECORD

REV	ECN	DESCRIPTION	DRFT	DATE
-----	-----	-------------	------	------

NOTES1:

UL Standard

1. Rated voltage/current : 300V / 10A
2. Withstanding voltage : AC1600V/1Min.
3. Wire range : 28~16AWG

IEC Standard

1. Pollution Degree	3
Overvoltage Category	III
Rate Impulse Voltage(KV)	8.0KV
Rate Voltage(V)	800V
Rate Current(A)	17.5A

2. Wire range : 0.2~1.5mm²

NOTES2:

1. Dimension shall be interpreted per ASME Y14.5-2009
2. Pitch : 5.0mm, Poles : N=01P
3. Stripping length : 7~8mm
4. Operating temperature : -40°C~+105°C
5. Undimensioned tolerances:

Pitch range in mm		Nominal dimension range in mm				0.1/10		
TO 6	Over 6 TO 10	Over 10 TO 24	TO 30	Over 30 TO 60	Over 60 TO 100		Over 100 TO 150	Over 150
±0.15	±0.20	±0.30	±0.30	±0.50	±0.70	±1.00	±1.30	±2*

6. RoHS Compliance

WS1.5-DB - 01P - 1Y - 00A (H)

(Series No.) (Poles) (Single Pitch) (Color): 1.(Grey)
 2.(Blue)
 3.(Black)
 4.(Green)
 5.(Orange)
 6.(Red)
 7.(Transparent)
 8.(Yellow)
 9.(White)

(RoHS)
 00A-(Standard)

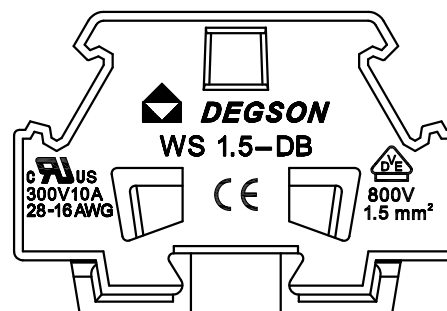
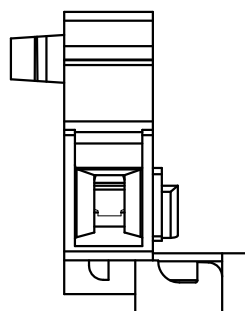
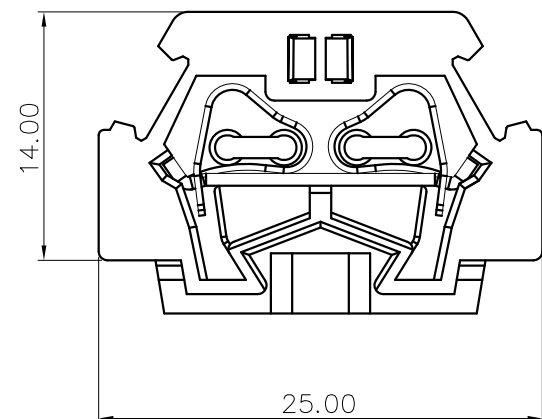
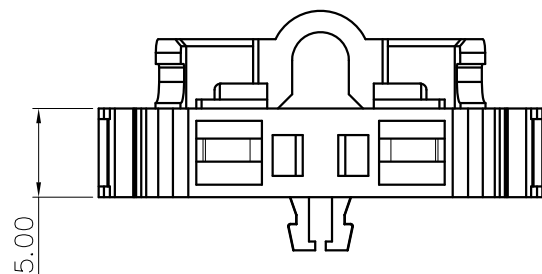

DETACHED LISTS	PART NO.:	/			
	APPD:	/			
	CHKD:	/			
	DRFT:	/			
	NAME:	NINGBO DEGSON ELECTRICAL CO., LTD			
		WS1.5-DB-01P-1Y-00A(H)			
	TITLE:	CUSTOMER DRAWING	REV	D0	
	DRAWING NO.:	/	SHEET	1/1	
	THIRD ANGLE PROJECTION	DO NOT SCALE DRAWING	SCALE	1:1	

H
G
F
E
D
C
B
A