

REVISION RECORD				
REV	ECD	DESCRIPTION	DRFT	DATE

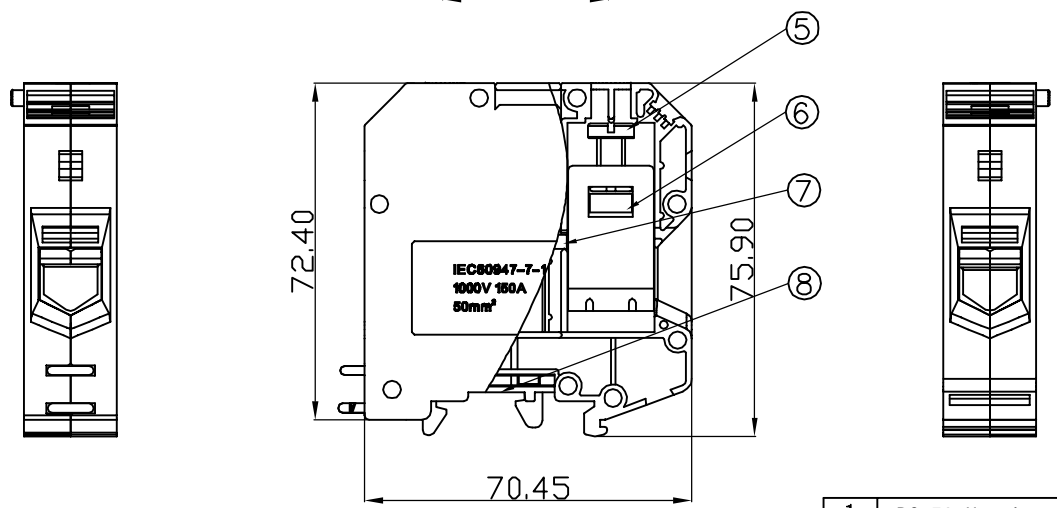
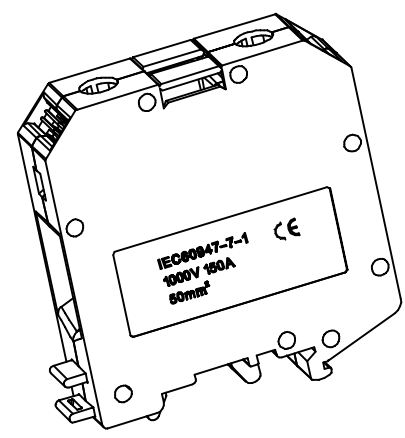
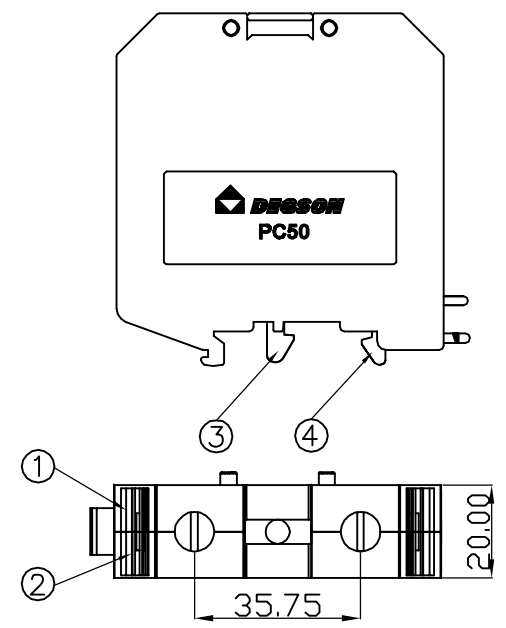

Notes

1. Operation temperatures: -40°C ~ +105°C
2. Wire Range: 6~0AWG, 50mm²
3. Max. Torque Value: M6, 25.5kgf. cm
4. Undimensioned Tolerances:

Pitch range in mm		Nominal dimension range in mm					—
to 6	over 6 to 10	over 10 to 24	to 30	over 30 to 60	over 60 to 100	over 100 to 150	∩
±0.10	±0.15	±0.25	±0.2	±0.3	±0.5	±0.7 ±1.0	◇

ITEM	DESCRIPTION	PART NO.	QTY	MATERIAL	FINISH
8	PC 50 Spring	X000001800(H)	1	Spring Steel	Ni Plated
7	PC 50-Current Carrier	6053B00010(H)	1	Copper	SnCe Plated
6	PC 50-Hardware	X00001850(H)	2	Iron	Cr ³⁺ Zn
5	PC 50 M6"-Screw	S000002510(H)	2	Steel	Cr ³⁺ Zn
4	PC 50-Slip Component Two	6053D1501C(H)	1	PA66	UL94V-0
3	PC 50-Slip Component One	6053D1501A(H)	1	PA66	UL94V-0
2	PC 50 Housing Two	6053A0Y01C(H)	1	PA66	UL94V-0

1	PC 50 Housing One	6053A0Y01A(H)	1	PA66	UL94V-0												
ITEM	NAME OF PART	NO. OF PART	Q'TY	MATERIAL	NOTES												
<table border="1"> <tr> <td>← MM (INCH) →</td> <td>DFTD ZYH</td> <td>DATE 01/12/08'</td> </tr> <tr> <td>TOLERANCES EXCEPT AS NOTED</td> <td>CHKD</td> <td>DATE</td> </tr> <tr> <td></td> <td>MFD</td> <td>DATE</td> </tr> <tr> <td></td> <td>APPVL</td> <td>DATE</td> </tr> </table>		← MM (INCH) →	DFTD ZYH	DATE 01/12/08'	TOLERANCES EXCEPT AS NOTED	CHKD	DATE		MFD	DATE		APPVL	DATE	宁波高正电子有限公司 DEGSON ELECTRONICS CO., LTD			
← MM (INCH) →	DFTD ZYH	DATE 01/12/08'															
TOLERANCES EXCEPT AS NOTED	CHKD	DATE															
	MFD	DATE															
	APPVL	DATE															
DETACHED LISTS		G.E		NAME PC50-01P-1Y-00A(H)													
<table border="1"> <tr> <td>MM</td> <td>±</td> </tr> <tr> <td>.0 ±</td> <td>±</td> </tr> <tr> <td>.00 ±</td> <td>±</td> </tr> <tr> <td>.000 ±</td> <td>±</td> </tr> </table>		MM	±	.0 ±	±	.00 ±	±	.000 ±	±	FINISH:		DRAWING NO. PC50-E01					
MM	±																
.0 ±	±																
.00 ±	±																
.000 ±	±																
ANGLES ± 1°		SCALE: 1:1		SIZE A4													
THIRD ANGLE PROJECTION		DO NOT SCALE DRAWING		REV TO 01/12/08'													
				SHEET 1 OF 1													