

REVISION RECORD				
REV	ECD	DESCRIPTION	DRFT	DATE
△		图面更新	LJH	09/18/08'

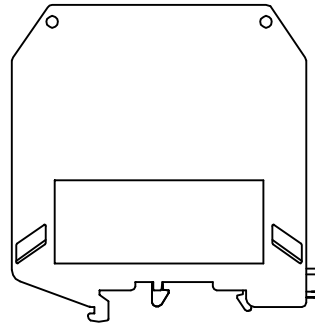

Notes:

1. Rated voltage/current:1000V/232A
2. Operation temperatures:-40° C~+105° C
3. Wire Range:35-95mm² 4~000AWG
4. Max. Torque Value:35.70kgf. cm
5. Undimensioned Tolerances:

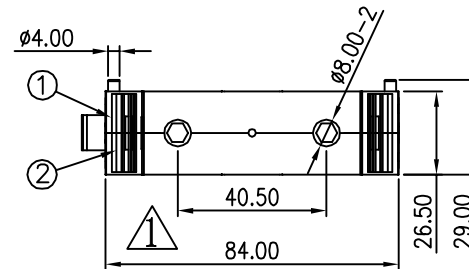

Pitch range in mm		Nominal dimension range in mm						—
to	over	over	to	over	over	over	over	∩
6	6	10	30	30	60	100	150	∇
	to	to	to	to	to	to		
	10	24	30	60	100	150		
	±0.10	±0.15	±0.25	±0.2	±0.3	±0.5	±0.7	±1.0
								0.05/10

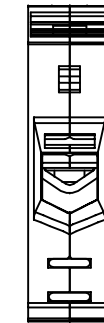
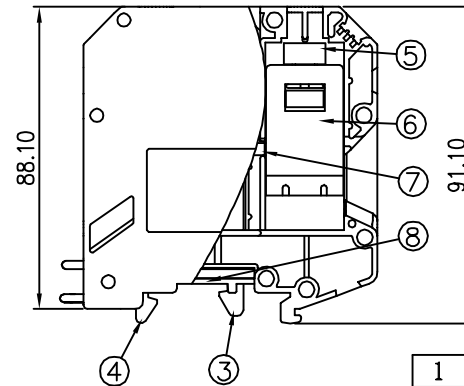

8	PC 95 Sping	1	Spring steel	Zn Plated
7	PC 95 -Current carrier	1	Copper	Ni Plated
6	PC 95 -Hardware	2	Iron	Zn Plated
5	PC 95M8 Hex socket screw	2	Steel	Zn Plated
4	PC 95 -Slip component two	1	PA66	UL94V-0
3	PC 95 -Slip component one	1	PA66	UL94V-0
2	PC 95 Housing two	1	PA66	UL94V-0

ITEM	NAME OF PART	NO. OF PART	Q'TY	MATERIAL	NOTES
1	PC 95 Housing one	1	1	PA66	UL94V-0

MM (INCH)	DFTD ZYH CHKD MFD APPVL	DATE 12/05/07' DATE DATE DATE	宁波高正电子有限公司 DEGSON ELECTRONICS CO., LTD
TOLERANCES EXCEPT AS NOTED	NAME PC95-01P-1Y-00A (外购、不环保)		
.0 ± .00 ± .000 ±	MATERIAL : G.E : FINISH:		
ANGLES ± 1° THIRD ANGLE PROJECTION	SCALE : 1:1 DRAWING NO. PC95-E01 /PART NO.		

DO NOT SCALE DRAWING	SHEET 1	OF 1
----------------------	---------	------