

REVISION RECORD				
REV	ECN	DESCRIPTION	DRFT	DATE

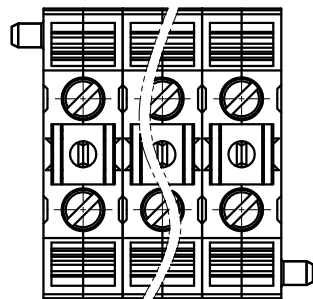

NOTES1:

UL Standard

- 1.Rated voltage/current : 600V / 70A
- 2.Torque value : M4 , 10.6Lb.in
- 3.Wire range : 24~6AWG

IEC Standard

- 1.Rated voltage/current : 450V / 57A
- 2.Torque value : M4 , 1.2N·m
- 3.Wire range : 0.2~10mm²

NOTES2:

- 1.Dimension shall be interpreted per ASME Y14.5-2009
- 2.Pitch : 10.00mm, Poles : N=01~XXP
- 3.Stripping length : 12mm
- 4.Withstanding voltage : AC2500V/1Min.
- 5.Operating temperature : -40°C~+105°C
- 6.Undimensioned tolerances:

Pitch range in mm		Nominal dimension range in mm					-	∩	□
TO	Over	Over	Over	Over	Over	Over	0.1/10		
6	10	10	30	60	100	150			
±0.15	±0.20	±0.30	±0.30	±0.50	±0.70	±1.00	±1.30	±2°	

7.RoHS Compliance

PS10 - XXP - 1Y - 10A (H)
 (Series No.) (Poles) (Single Pitch) (Color): 1.(Grey)
 2.(Blue)
 3.(Black)
 4.(Green)
 5.(Orange)
 6.(Red)
 7.(Transparent)
 8.(Yellow)
 9.(White)

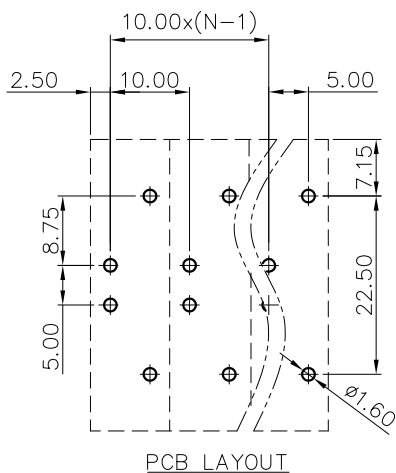
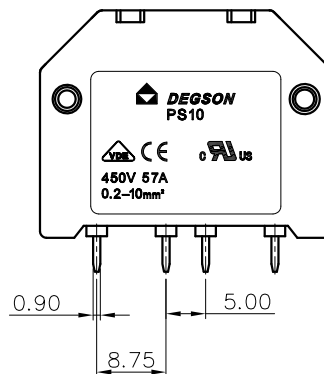
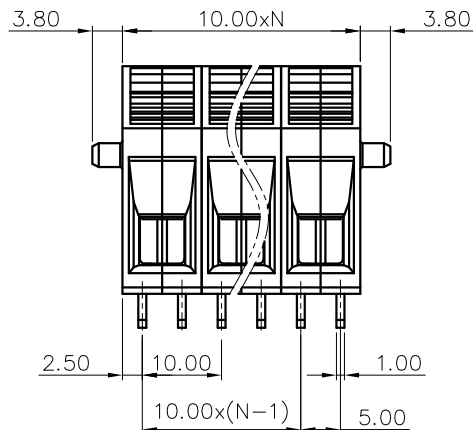
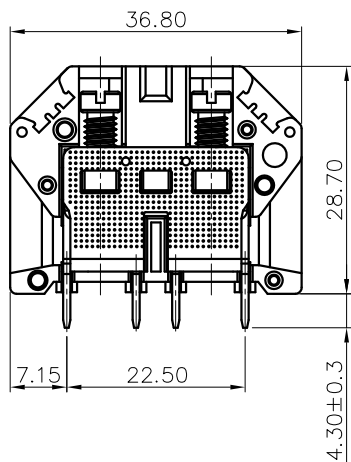

DETACHED LISTS	PART NO.:	/			
	APPD:	/			
	CHKD:	/			
	DRFT:	/			
	THIRD ANGLE PROJECTION		DO NOT SCALE DRAWING		SCALE: 1:1

PART NO.: /		宁波高松电子有限公司 DEGSON NINGBO DEGSON ELECTRICAL CO., LTD	
APPD: /		NAME: PS10-XXP-1Y-10A(H)	
CHKD: /		TITLE: CUSTOMER DRAWING	
DRFT: /		REV	DO
DRAWING NO.: /		SHEET	1/1