

REVISION RECORD				
REV	ECN	DESCRIPTION	DRFT	DATE

NOTES1:

UL Standard

- 1.Rated voltage/current : 300V / 10A
- 2.Torque value : M2.6 , 3.01~3.54Lb.in
- 3.Wire range : 26~14AWG

IEC Standard

- 1.Rated voltage/current : 450V / 18A
- 2.Torque value : M2.6 , 0.34~0.40N·m
- 3.Wire range : 0.5~2.5mm²

NOTES2:

- 1.Dimension shall be interpreted per ASME Y14.5-2009
- 2.Pitch : 7.5mm, Poles : N=02~03P
- 3.Stripping length : 5-6mm
- 4.Withstanding voltage : AC2500V/1Min
- 5.Operating temperature: -40°C~+105°C
- 6.Undimensioned tolerances:

Pitch range in mm		Nominal dimension range in mm						0.1/10
TO	Over	TO	Over	TO	Over	TO	Over	
6	10	10	24	30	60	100	150	0.1/10
±0.15	±0.20	±0.30	±0.30	±0.50	±0.70	±1.00	±1.30	±2'

7.RoHS Compliance

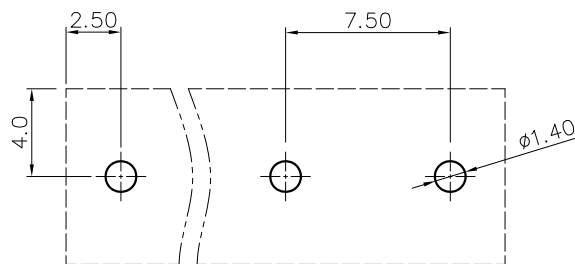
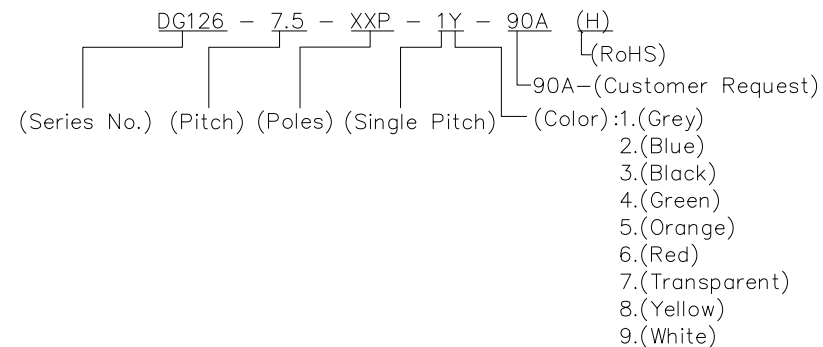
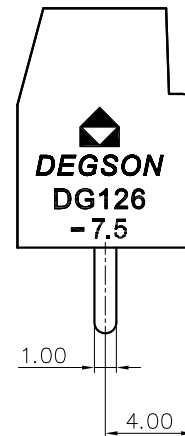
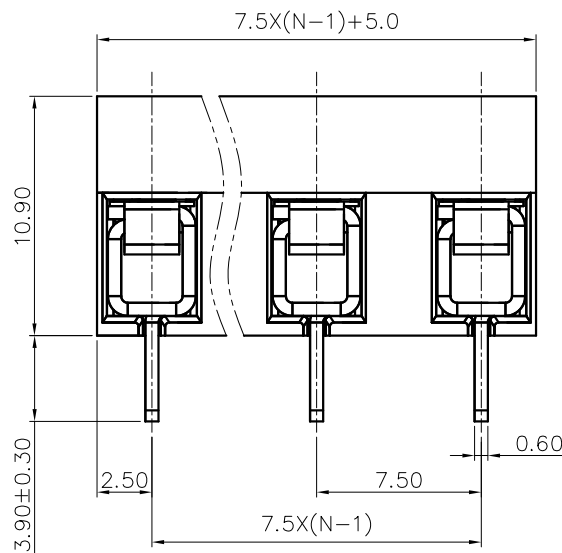
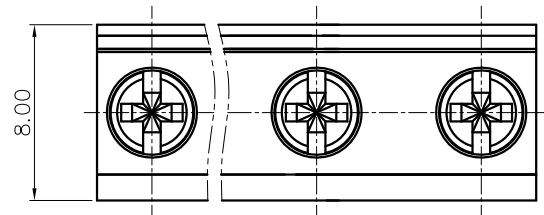
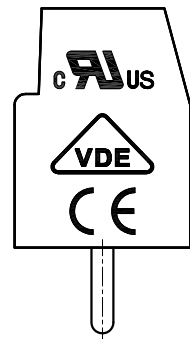

PCB LAYOUT

DETACHED LISTS	PART NO.:	NINGBO DEGSON ELECTRICAL CO., LTD			
	APPD:	NAME: DG126-7.5-XXP-1Y-90A(H)			
	CHKD:	TITLE: CUSTOMER DRAWING		REV	DO
	DRFT:	DRAWING NO.:		SHEET	1/1
THIRD ANGLE PROJECTION		MM (INCH)	DO NOT SCALE DRAWING	SCALE	1:1