

REVISION RECORD				
REV	ECN	DESCRIPTION	DRFT	DATE

H
G
F
E
D
C
B
A

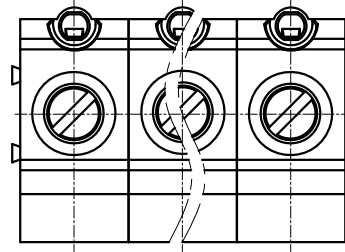

NOTES1:

UL Standard

- 1.Rated Voltage/Current : 300V / 60A
- 2.Torque Value : M4 , 10.53Lb.in
- 3.Wire Range : 20~6AWG

IEC Standard

- 1.Rated Voltage/Current : 1000V / 65A
- 2.Torque Value : M4 , 1.2N.m
- 3.Wire Range : 2.5~16.0mm²

NOTES2:

- 1.Dimension shall be interpreted per ASME Y14.5-2009
- 2.Pitch : 10.16mm, Poles : N=01~XXP
- 3.Stripping length : 10~11mm
- 4.Withstanding Voltage : AC3500V/1Min.
- 5.Operating temperature: -40°C~+105°C
- 6.Undimensioned Tolerances:

Pitch range in mm		Nominal dimension range in mm				Tolerances	
TO	Over TO	TO	Over TO	TO	Over TO	0.1/10	∠
6	10	30	60	100	150	<	
±0.15	±0.20	±0.30	±0.50	±0.70	±1.00	±1.30	±2°

7.RoHS Compliance

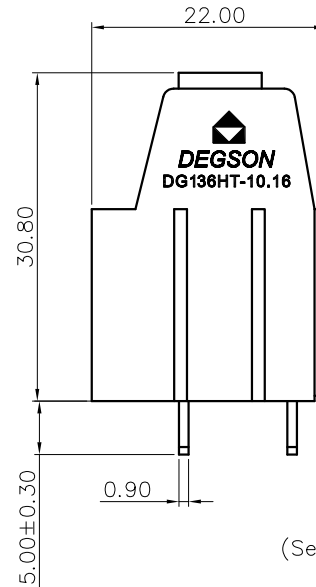
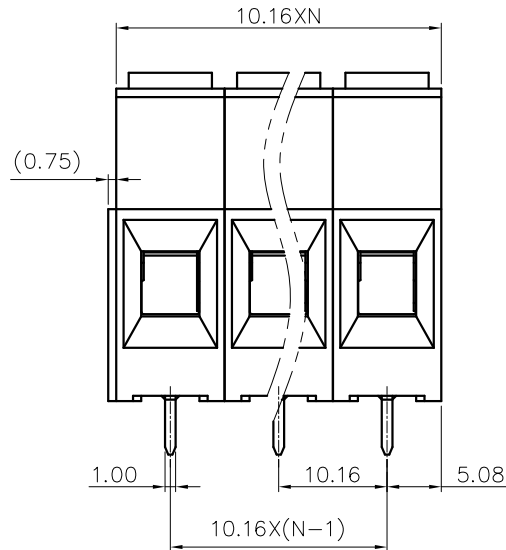
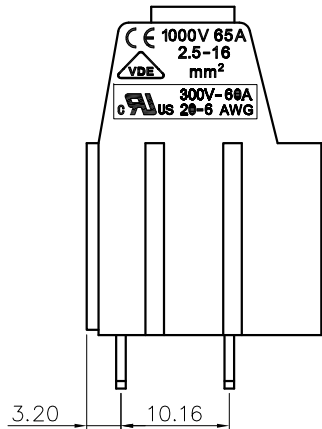

DG136HT -10.16 - XXP - 1Y - 00A (H)
 (Series No.) (Pitch) (Poles) (Single Pitch)(Color):1.(Grey)
 2.(Blue)
 3.(Black)
 4.(Green)
 5.(Orange)
 6.(Red)
 7.(Transparent)
 8.(Yellow)
 9.(White)

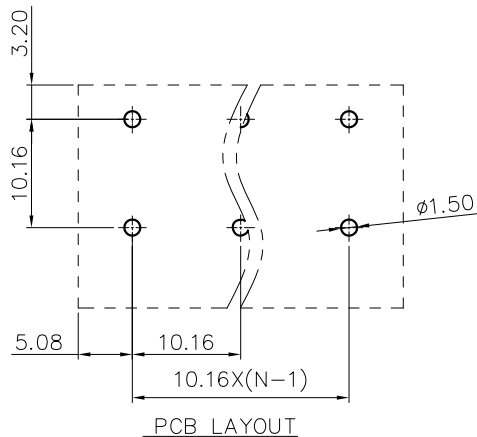

DETACHED LISTS	PART NO.:	NINGBO DEGSON ELECTRICAL CO., LTD		
	APPD:	NAME: DG136HT-10.16-XXP-1Y-00A(H)		
	CHKD:	TITLE: CUSTOMER DRAWING		REV
	DRFT:	DRAWING NO.:		DO
THIRD ANGLE PROJECTION		MM (INCH)	DO NOT SCALE DRAWING	SCALE 1:1