

REVISION RECORD

REV	ECN	DESCRIPTION	DRFT	DATE
-----	-----	-------------	------	------

NOTES1:

UL Standard

- 1.Rated voltage/current : 300V / 30A
- 2.Torque value : M3 , 4.43Lb.in
- 3.Wire range : 24~10AWG

IEC Standard

1. Pollution degree	2	2	3
Overvoltage category	II	III	III
Rate impulse voltage(kV)	6.0KV	6.0KV	6.0KV
Rate voltage(V)	1000V	630V	450V
Rate current(A)	32AA		

- 2.Torque value : M3 , 0.5N·m
- 3.Wire range : 0.5~6.0mm²

NOTES2:

- 1.Dimension shall be interpreted per ASME Y14.5-2009
- 2.Pitch : 7.62mm, Poles : N=02~XXP
- 3.Stripping length : 13-14mm
- 4.Withstanding voltage : AC1600V/1Min.
- 5.Operating temperature: -40°C~+105°C
- 6.Undimensioned tolerances:

Pitch range in mm		Nominal dimension range in mm						
Over 6 TO 10	Over 10 TO 24	Over 30 TO 60	Over 60 TO 100	Over 100 TO 150	0.1/10			
±0.15	±0.20	±0.30	±0.30	±0.50	±0.70	±1.00	±1.30	±2'

7.RoHS Compliance

DG107V - 7.62 - XXP - 1Y - 00A (H)

(Series No.) (Pitch) (Poles)(Single Pitch) (Color):1.(Grey)
 2.(Blue)
 3.(Black)
 4.(Green)
 5.(Orange)
 6.(Red)
 7.(Transparent)
 8.(Yellow)
 9.(White)

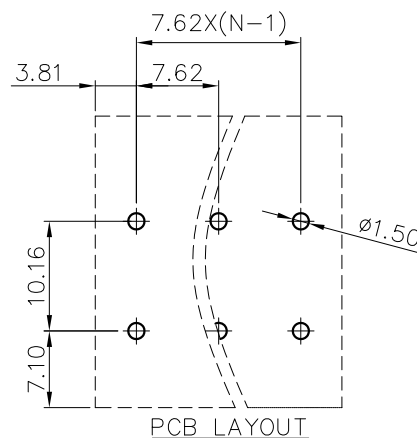
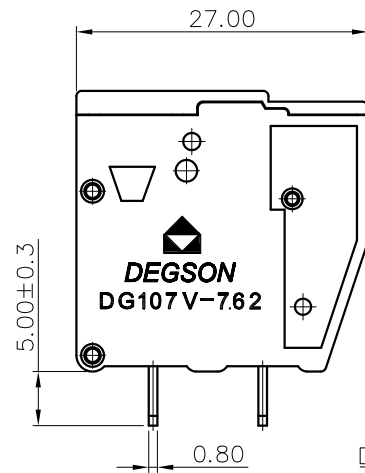
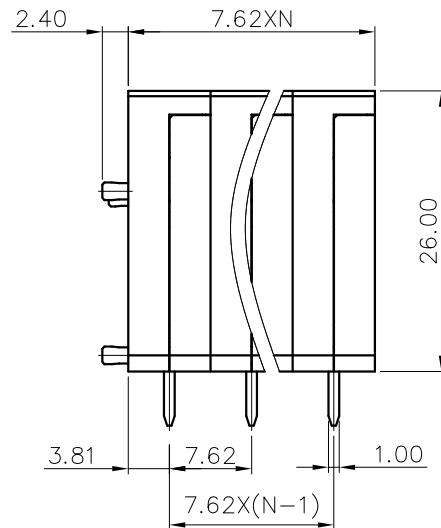
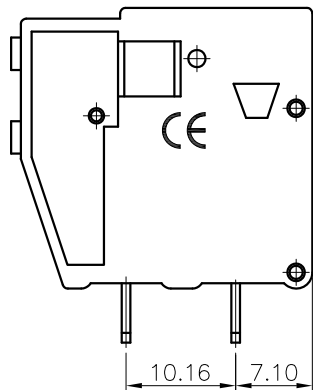
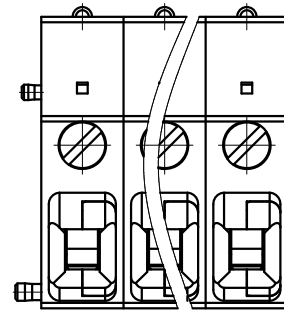

DETACHED LISTS	PART NO.:	/			
	APPD:	/			
	CHKD:	/			
	DRFT:	/			
	NAME:	NINGBO DEGSON ELECTRICAL CO., LTD			
		DG107V-7.62-XXP-1Y-00A(H)			
	TITLE:	CUSTOMER DRAWING	REV	D0	
	DRAWING NO.:	/	SHEET	1/1	
	THIRD ANGLE PROJECTION	MM (INCH)	DO NOT SCALE DRAWING	SCALE	1:1