

REVISION RECORD				
REV	ECN	DESCRIPTION	DRFT	DATE

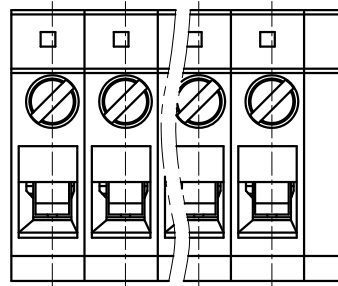

NOTES1:
 UL Standard
 1.Rated voltage/current : 300V / 20A
 2.Torque Value : M2.5 , 4.4Lb.in
 3.Wire range : 30~12AWG
 IEC Standard
 1.Rated voltage/current : 250V / 24A
 2.Torque Value : M2.5 , 0.4N.m
 3.Wire range : 0.5~2.5mm²

NOTES2:
 1.Dimension shall be interpreted per ASME Y14.5-2009
 2.Pitch : 5.00mm, Poles : N=02~XXP
 3.Stripping length : 13-14mm
 4.Withstanding voltage : AC2000V/1Min.
 5.Operating temperature: -40°C~+105°C
 6.Undimensioned tolerances:

Pitch range in mm		Nominal dimension range in mm				□	∇									
To	Over	To	To	To	To	0.1/10	≤									
6	10	10	24	30	60	100	150	±0.15	±0.20	±0.30	±0.30	±0.50	±0.70	±1.00	±1.30	±2'

7.RoHS Compliance

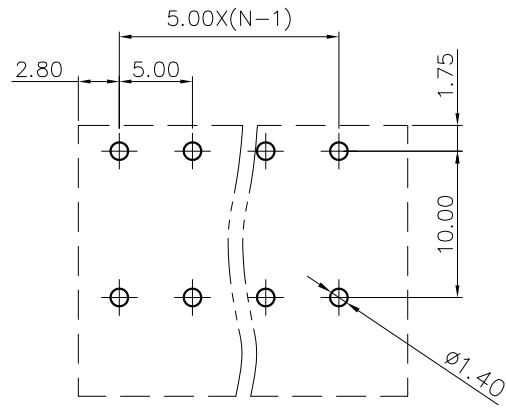
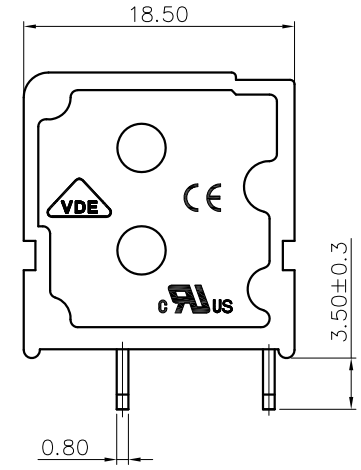
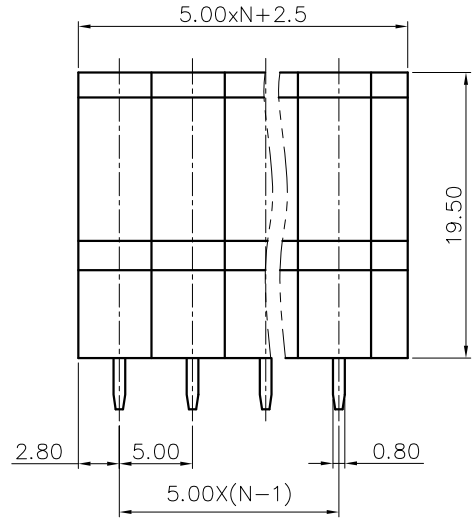
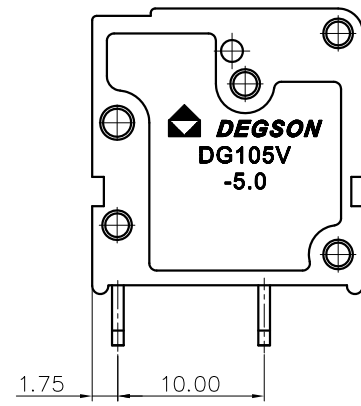

PCB LAYOUT

DG105V - 5.0 - XXP - 1Y - 10A (H)
 (Series No.) (Pitch) (Poles) (Single Pitch) (Color)
 (RoHS)
 10A-(Standard)
 1.(Grey)
 2.(Blue)
 3.(Black)
 4.(Green)
 5.(Orange)
 6.(Red)
 7.(Transparent)
 8.(Yellow)
 9.(White)

DETACHED LISTS	PART NO.:	/			
	APPD:	/			
	CHKD:	/			
	DRFT:	/			
		THIRD ANGLE PROJECTION			
		MM (INCH)		DO NOT SCALE DRAWING	
		DRAWING NO.: /		REV	DO
		SHEET 1/1		SCALE	1:1

宁波高松电子有限公司
 NINGBO DEGSON ELECTRICAL CO., LTD

NAME: DG105V-5.0-XXP-1Y-10A(H)

TITLE: CUSTOMER DRAWING

DRAWING NO.: /

DO NOT SCALE DRAWING

REV

DO

SHEET 1/1

SCALE 1:1